

# Artisan Series



Featuring quality hand-crafted cases in solid hardwood or contemporary plastic laminate.

The ARTISAN SERIES, DRAPER's finest projection screens, are enclosed in solid hardwood cases with a variety of finishes to match virtually any decor—or in sleek, contemporary plastic laminate. Hardwood cases are available in your choice of rectilinear, radius, traditional or bevel styles; laminate cases are constructed in contemporary rectilinear style. Custom finishes are also available.

## Artisan/Series V

ARTISAN/SERIES V—Featuring DRAPER's TAB TENSIONING SYSTEM, for a perfectly flat viewing surface. Holds surface taut and wrinkle-free, eliminating edge curl. The perfectly flat viewing surface allows for pin-point accuracy in converging sophisticated video and data projectors. Projected image is framed by standard black masking borders. M1300 and M2500 projection surfaces available.

## Artisan/Series E

ARTISAN/SERIES E—Motor-in-roller operation, with a variety of controls available (see page 19). Viewing surfaces in fiberglass matt white, glass beaded, or PANAMAX. See below for standard sizes, styles and finishes—or request a quotation if your project requires a custom size or finish.

## Case Styles and Finishes for Series V and Series E (& Series M, page 21)

### Case Styles

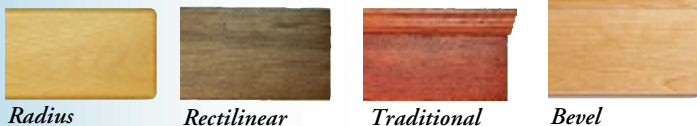

### Solid Hardwoods

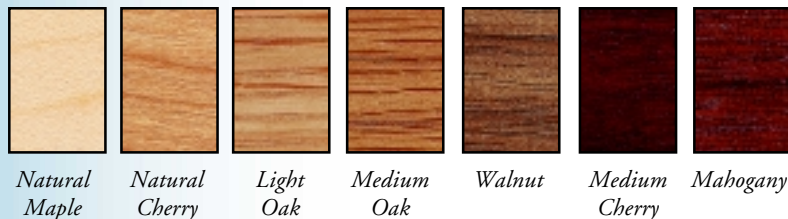

### Plastic Laminates (rectilinear case style only)

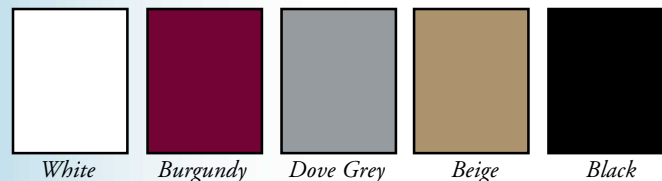

### Optional Equipment

- **Extra Drop**—Up to 8' total screen height, either white or black (White is standard for AV format; black for all other formats).
- **Black Masking Borders**—Borders are optional for SERIES E in AV format. They are standard for all SERIES V screens, and for SERIES E in all other formats.
- **Control Options**—Refer to page 19.
- **Colors and Finishes**—Shown above.

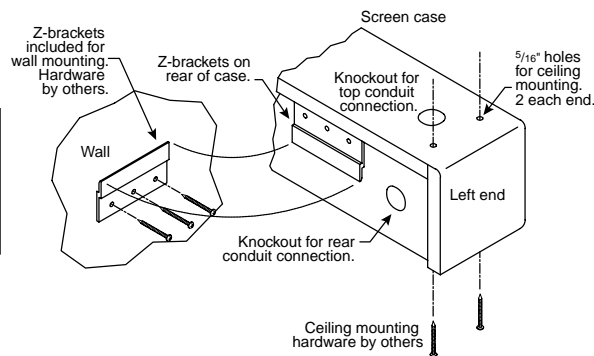
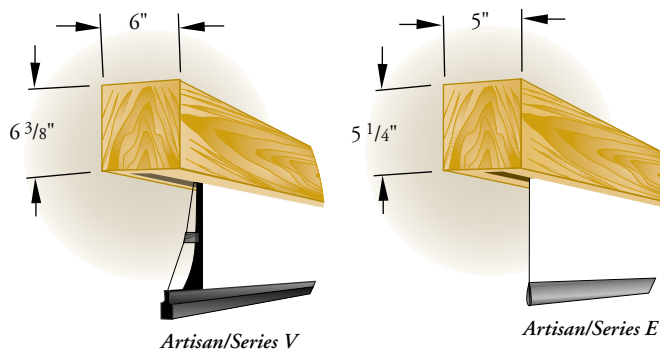

These colors match as closely as is possible on the printed page. Samples available for color matching. Custom finishes available.

Size H x W	Series E	Series V	Series E		Series V	
	Shipping Wt. (lbs.)	Shipping Wt. (lbs.)	Nominal Diagonal	Viewing Area	Shipping Wt. (lbs.)	Viewing Area
<b>Audio Visual Format</b>						
50" x 50"	65	70	<b>NTSC Format (3:4)</b>			
60" x 60"	70	75	6'	42½" x 56½"	70	42½" x 56½"
70" x 70"	80	85	7'	50" x 66½"	80	50" x 66½"
84" x 84"	90	100	100"	60" x 80"	90	60" x 80"
6' x 8'	95	105	10'	69" x 92"	95	72" x 96"
8' x 8'	100	110	<b>HDTV Format (9:16)</b>			
			92"	45" x 80"	90	45" x 80"
			106"	52" x 92"	95	52" x 92"
<b>WideScreen Format (1:1.85)</b>						
8'/100"			47"	47" x 87"	93	47" x 87"
9'			50"	50" x 92"	95	50" x 92"